

KOHL'S

MINIMUM PACKING AND PRESENTATION STANDARDS

This document contains information regarding packing, packaging, and Micro-Pak/anti-bacterial shoebox requirements.

MINIMUM PACKING AND PRESENTATION STANDARDS

Contents

Packaging Requirements

Packaging Components 3-5

Hanging Footwear Packaging 6

Boxed Footwear Packaging 7-22

Packing Requirements

Sample Packaging 23-25

Polybag Guidelines 26-30

Shoebox Requirements

Micro-Pak Guidelines 31-33

Anti-Bacterial/Anti-Fungal Wasaouro Guidelines 34-35

MINIMUM PACKING AND PRESENTATION STANDARDS

Packaging Requirements

Packaging Components

Packaging Components for Boxed Footwear – for retail store orders only	
<p>NOTE: "E-commerce specific POs require packaging specific to the Kohl's e-commerce fulfillment process. The requirements can be found at the following location within the vendor portal (KOHL'S Connection): Logistics & Routing tab, Appendices link, Appendix SP-12 E-commerce Packaging Requirements."</p>	
<p>Recyclable Shoebox Made From Mostly Post-Consumer Materials.</p> <p>650 gram Minimum Weight MUST BE Written On Purchase Orders To Box Supplier.</p>	<p>Order from KOHL'S designated KOHL'S shoebox supplier: Boxes Shop - Nan Chieh Paper Products Co., Ltd. (office) No. 1123 Wen Hsing South 3rd Rd. Taichung City, Taiwan R.O.C. Jay Huang sales@boxes-shop.com Mobile #: 714-9315419 or PH #: 886-4-23852207</p>
<p>Recycled Paperboard Divider</p>	<p>USE vertical divider placed in between left & right shoe/boot in the box. For tall boots USE a flat divider placed in between left & right boot in the box.</p>
<p>Vamp Inserts & Upper Supports</p>	<p>Inserted into footwear to support vamp / upper. USE tissue, formed tissue, diecut & folded paperboard, or molded paper pulp forms. DO NOT USE molded plastic forms, foam blocks, or plastic clips.</p>
<p>Topline Sticks</p>	<p>Inserted into footwear to hold the topline shape. ONLY USE engineered bamboo topline sticks. Suppliers on p. 7. DO NOT USE raw bamboo, or plastic topline sticks</p>
<p>Paper Tissue Runner & Wrap</p>	<p>1 pc. of tissue runner in bottom of box, extending over box ends. 1 pc. of tissue wrap. Fold both end of tissue runner into box. Fold both ends of tissue wrap into box, one sheet overlapping the other. USE post consumer (recycled) paper tissue. Order from: Boxes Shop - Nan Chieh Paper Products Co., Ltd. (see above)</p>
<p>Anti-Bacterial / Anti-Fungal Chips</p>	<p>Use Micro-Pak® or Wasaouro® self-adhesive Anti-Bacterial / Anti-Fungal chips w/ KOHL'S logo. Refer to illustrations for placement in packaging. DO NOT USE silica gel packets or any other brands of anti-mold chips.</p>
<p>Anti-Bacterial / Anti-Fungal Oil for Cartons</p>	<p>Tissue with Wasaouro® Anti-Bacterial /Anti-Fungal oil placed in each carton per manufacturer's instructions.</p>
<p>Staples</p>	<p>DO NOT USE STAPLES for footwear packaging, i.e. assembling shoeboxes, assembling quarter strap supports, etc.</p>
<p>NOTE: Refer to product specifications for packaging details specific to each style.</p>	

MINIMUM PACKING AND PRESENTATION STANDARDS

Packaging Components for Hanging Footwear Programs (no shoebox) for retail store orders only

NOTE: "E-commerce specific POs require packaging specific to the Kohl's e-commerce fulfillment process. The requirements can be found at the following location within the vendor portal (KOHL'S Connection): Logistics & Routing tab, Appendices link, Appendix SP-12 E-commerce Packaging Requirements."

Polybag: "shipping carton liner"	Perforated, 4.0 mil, polyethylene bag w/suffocation warning printed directly on each polybag. Bag size will vary with shipping carton size. Fold over open bag end to cover carton contents.
Foam Toe Thong Support	The preferred option for a thong sandal needing upper support. Specifically designed to fit securely around the toe thong so it stays in place during shipping.
Vamp Tissue	In general, do not use tissue balls to stuff uppers of any hanging footwear programs, <u>especially flip-flops</u> . However there will be some exceptions because of pattern design, which should be detailed on the Packaging & Labeling page of the product specs. Contact the product manager or technical design if there are any questions.
Diecut & Folded Paperboard Upper Supports	Inserted into footwear requiring upper support. DO NOT stuff uppers with paper tissue balls because they do not stay in place during shipping
Elastic Cord	Ties 2 shoes of a pair together. 255 mm (10") long. Ends knotted together.
Hang Tags	All hang tags should be attached to the LEFT shoe. DO NOT attach hang tag through elastic chord used to tie footwear together.
Recyclable PET plastic hanger w/hooks NOTE: cost includes hanger, logo sticker, & size sticker	Nan Jump Paper-Product Co., Ltd Xia Dong Industrial park, Ping Liu Road, Pingzhou Nanhai Foshan City, Guangdong China Tel: 86-757-86229668 / 86322161 Fax: 86-757-86221198 Contact -1: Alex Ko - Cell: 86-13322844698 Email: alex@boxes-shop.com Contact - 2: Wei Lo - Cell: 86-13326751220 Email: nanjump@boxes-shop.com
Recyclable PET plastic hanger w/clip - CJ-17294	For hanging footwear styles, i.e. boots, that get clipped together at the toplines because hooks can't be inserted into the vamp. Order from: Chung Chieh Plastic Industrial Co., Ltd. PH#: 86-769-83043088 FX#: 86-769-85584171 Salesman: James Win Email: Jameswin@cj94168.com Mobile #: 86-13924349060
Anti-Bacterial / Anti-Fungal for Carton	Tissue with Wasaouro® Anti-Bacterial / Anti-Fungal oil placed into each polybag carton liner per supplier's instructions.
Staples	DO NOT USE STAPLES for footwear packaging, i.e. assembling quarter strap supports, sealing polybags, etc.

NOTE: Refer to product specifications for packaging details specific to each style.

MINIMUM PACKING AND PRESENTATION STANDARDS

Paper Tissue Specifications (1 pc. bottom runner & 1 pc. footwear wrap):

LOGO	CANDIES JUNIORS	LC	SO JUNIORS	SIMPLY VERA WANG	JL	APT.9 MNS & WMS	CROFT & BARROW MNS & WMS	SONOMA MNS & WMS	JUMPING BEANS
WEIGHT	18 gms Cotton paper (more translucent) KOH-WG2-CD	18 gms Cotton paper KOH-WMTS-LC	18 gms Cotton paper KOH-WG2-SO	18 gms Double Kao paper (more translucent) KOH-TSS-SV	18 gms Double Kao paper KOH-TSS-JL	18 gms Cotton paper (Included w/ box)	18 gms Cotton paper KOH-TCB1-CB	18 gms Cotton paper KOH-W614-SN	18 gms Cotton paper (Included w/ box)
COLOR	WHITE PRINT: PMS 871C LOGO	WHITE PRINT: PMS 871 LOGO	WHITE PRINT: PMS 701U LOGO	WHITE PRINT: WHITE LOGO	WHITE PRINT: SILVER LOGO	WHITE PRINT: NAVY LOGO	WHITE PRINT: PMS 289U LOGO	WHITE PRINT: PMS 1545U LOGO	WHITE NO PRINT
BURSTING STRENGTH kgf/CM2	1.50/kg	1.50/kg	1.50/kg	1.50/kg	1.50/kg	1.50/kg	1.50/kg	1.50/kg	1.50/kg
BRIGHTNESS cd/m2	80.82	80.82	80.82	83.18	83.18	80.82	80.82	80.82	80.82
CALIPER	0.031m/m	0.031m/m	0.031m/m	0.031m/m	0.031m/m	0.031m/m	0.031m/m	0.031m/m	0.031m/m
ACIDITY ph	5.4-5.6	5.4-5.6	5.4-5.6	5.6-6.0	5.6-6.0	5.4-5.6	5.4-5.6	5.4-5.6	5.6-6.0
WEAR RESISTANCE	4.5	4.5	4.5	4	4.5	4.5	4.5	4.5	4.5

LOGO	SO GIRLS	SONOMA KIDS
WEIGHT	18 gms Cotton paper (Included w/ box)	18 gms Cotton paper KOH-W616-SN
COLOR	PMS 466C PRINT: PMS 234C LOGO	WHITE PRINT: PMS 158C LOGO
BURSTING STRENGTH kgf/CM2	1.50/kg	1.50/kg
BRIGHTNESS cd/m2	80.82	80.82
CALIPER	0.031m/m	0.031m/m
ACIDITY ph	5.4-5.6	5.4-5.6
WEAR RESISTANCE	4.5	4.5

MINIMUM PACKING AND PRESENTATION STANDARDS

Hanging Footwear Packaging

Recyclable PET Footwear Hangers

So Hangers Orderable from Nan Jump

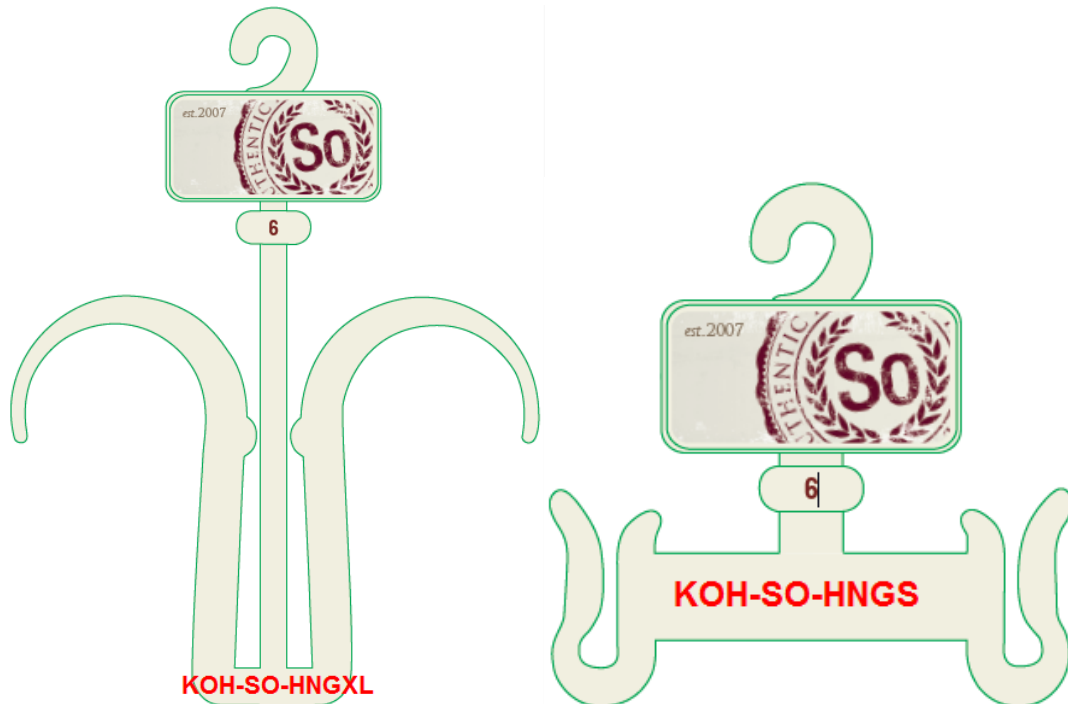
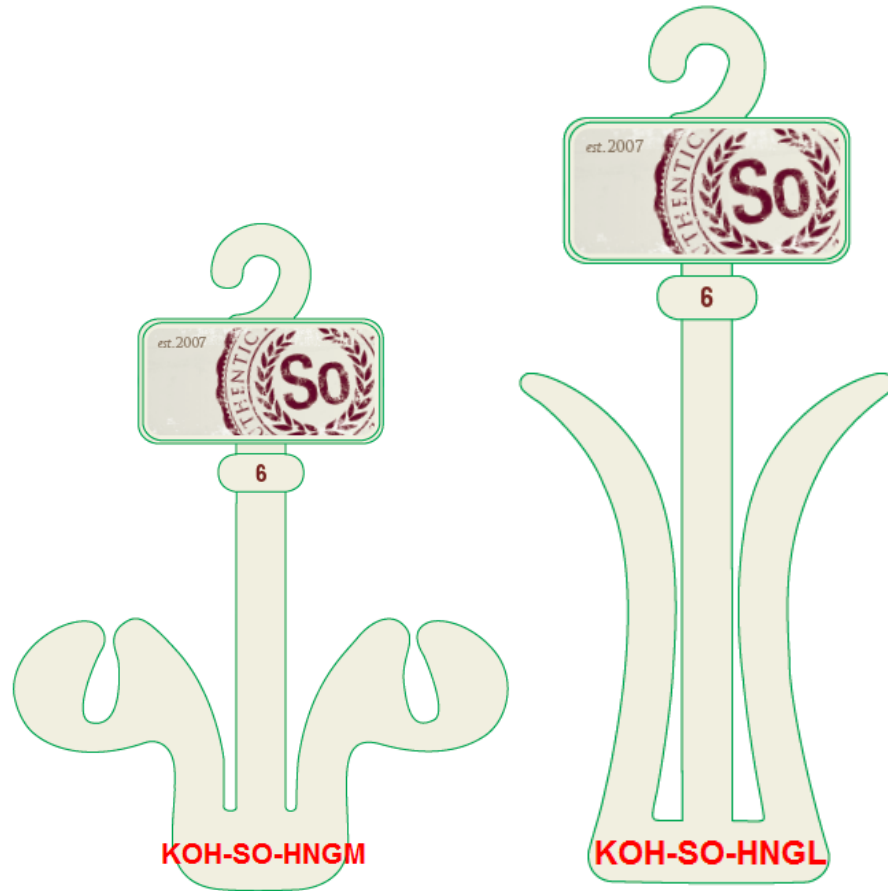

MINIMUM PACKING AND PRESENTATION STANDARDS

Boxed Footwear Packaging

Kohl's Standard Packaging: Boxed Footwear * with Divider

Ref. # 1

*This packaging also applies to ankle height footwear ie high top sneakers/ sneaker wedges, hikers, ankle booties

1. Apply Micro-Pak sticker to middle corner of long side of shoebox, at the same end of shoebox that the retail label is attached

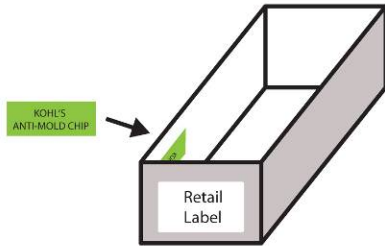

2. Tissue wrap length (1PC)=
 $2 \times \text{box width} + 3 \times \text{box height}$
Tissue runner length (1PC)=
 $2 \times \text{box length} + 2 \times \text{box height}$

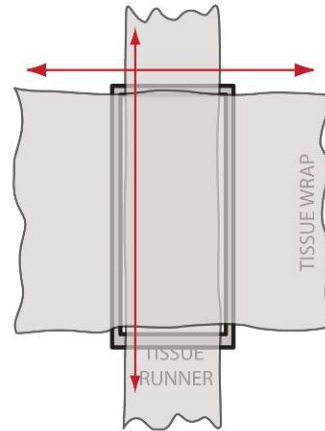

3. Place shoes in box

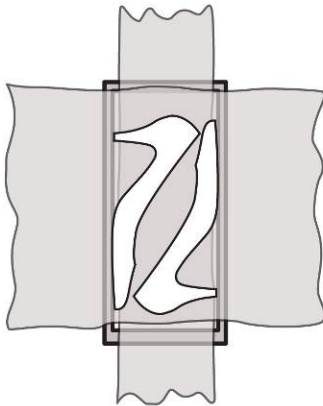

4. Place recycled paperboard divider between shoes

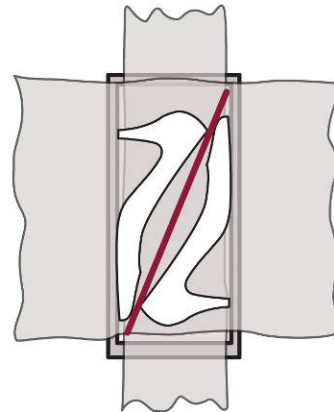

5. Fold both ends of tissue runner into box

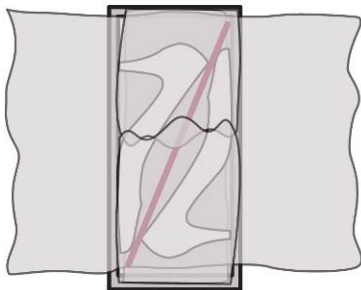

6. Fold both ends of tissue wrap into box, one sheet overlapping the other.



8/06/13

MINIMUM PACKING AND PRESENTATION STANDARDS

Any exception to the below Minimum Packaging and Presentation Standards need to be presented to and approved by TD and PD, with approval noted on confirmation checklist, 6-8 weeks prior to x-factory.

Kohl's Standard Packaging: Minimum* Boxed Footwear Packaging

Ref. # 2

*Examples: athletic shoes, river sandals, moccasins, unconstructed footwear (no heel counter, toe box, or lining). When not using a paperboard divider, please use tissue wrap as a divider in its place (illustration below). If you are unsure if your shoe needs a paperboard divider, please contact your TD for confirmation.

1. Apply Micro-Pak sticker to middle corner of long side of shoebox, at the same end of shoebox that the retail label is attached

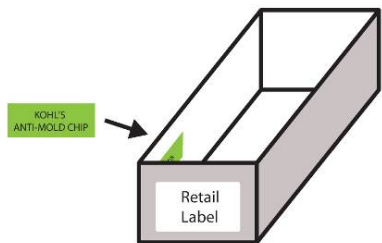

2. Tissue wrap length (1PC)=
 $2 \times \text{box width} + 3 \times \text{box height}$
Tissue runner length (1PC)=
 $2 \times \text{box length} + 2 \times \text{box height}$

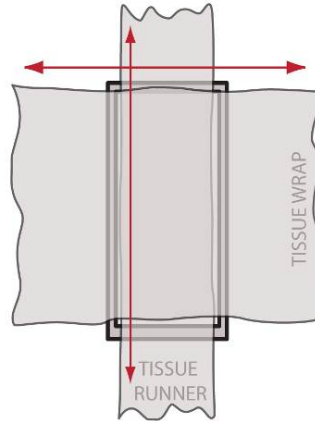

3. Place first shoe into box against one end and fold tissue on top of shoe to act as a divider

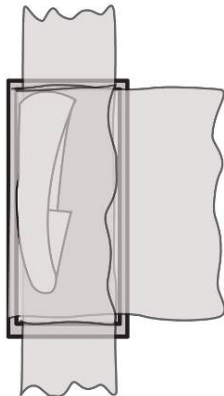

4. Place second shoe in box

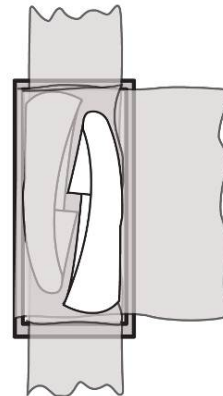

5. Fold both ends of tissue runner into box

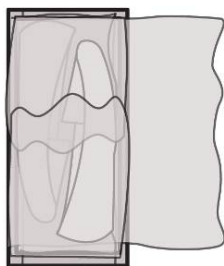

6. Fold other end of tissue wrap into box



5/29/13

MINIMUM PACKING AND PRESENTATION STANDARDS

Any exception to the below Minimum Packaging and Presentation Standards need to be presented to and approved by TD and PD, with approval noted on confirmation checklist, 6-8 weeks prior to x-factory.

Kohl's Standard Packaging: Boots* (w/ Paperboard Divider)

Ref. # 3

*Please reference packaging illustration "Ref. #1" for ankle height boots ie high top sneakers/ sneaker wedges, hikers, ankle booties

1. Apply 2 Micro-Pak stickers, one on each long side of shoebox in the center corner, at the same end of shoebox that the retail label is attached

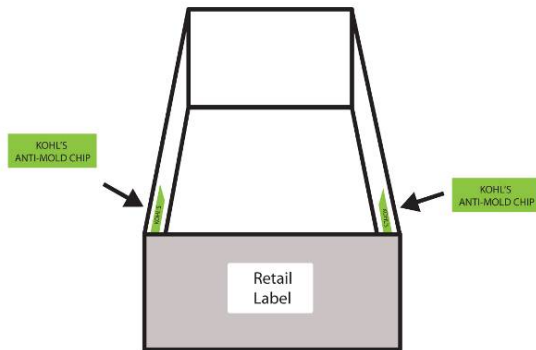

2. Tissue wrap length (1PC)=
 $2 \times \text{box width} + 3 \times \text{box height}$

Tissue runner length (1PC)=
 $2 \times \text{box length} + 2 \times \text{box height}$

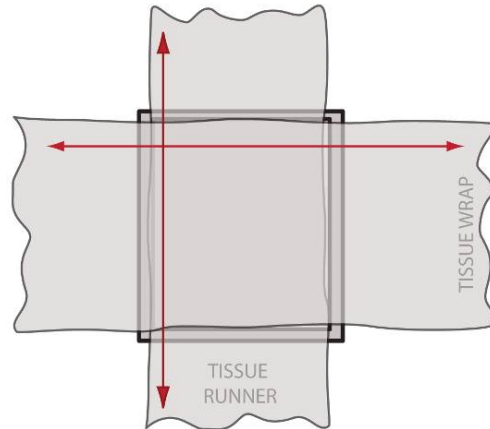

3. Place boot into box against one end

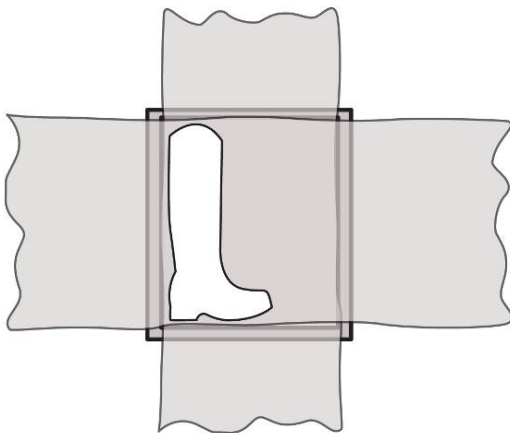

4. Place full sheet of recycled paper board divider into box over boot and place second boot on top of the divider

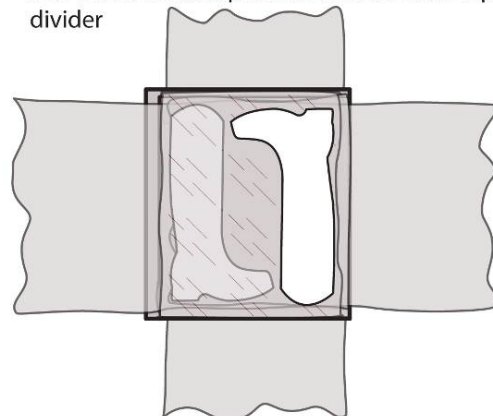

5. Fold both ends of tissue runner into box,

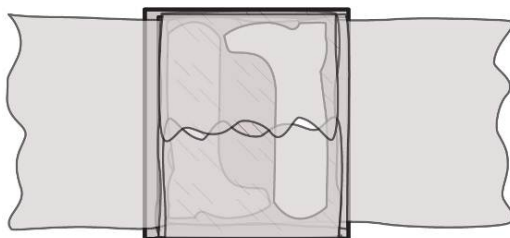

6. Fold both ends of tissue wrap into box, one sheet overlapping the other.

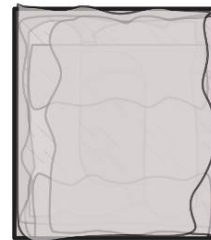

8/06/13

MINIMUM PACKING AND PRESENTATION STANDARDS

Any exception to the below Minimum Packaging and Presentation Standards need to be presented to and approved by TD and PD, with approval noted on confirmation checklist, 6-8 weeks prior to x-factory.

Kohl's Standard Packaging: Boots (w/o Paperboard Divider*)

Ref. # 4

*Boots without hardware (including zippers/ ornamentation) do not require a paperboard divider. When not using a paperboard divider, please use tissue wrap as a divider in its place (illustration below). If you are unsure if your boot needs a paperboard divider, please contact your TD for confirmation.

1. Apply 2 Micro-Pak stickers, one on each long side of shoebox in the center corner, at the same end of shoebox that the retail label is attached

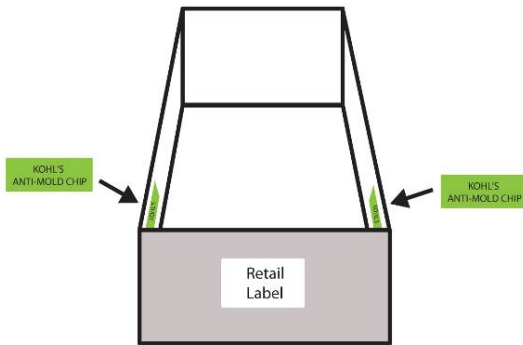

2. Tissue wrap length (1PC)=
2 X box width + 3 X box height

Tissue runner length (1PC)=
2 X box length + 2 X box height

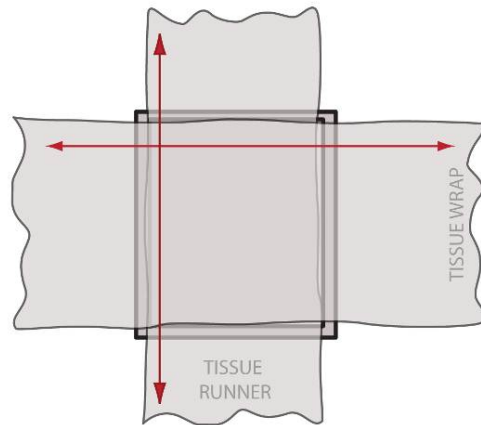

3. Place first boot into box against one end and fold tissue on top of boot to act as a divider

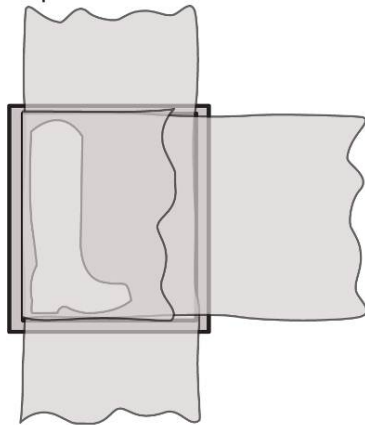

4. Place second boot in box

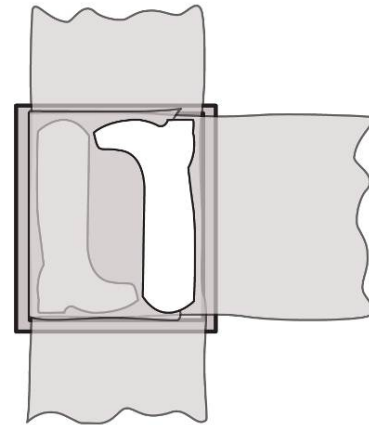

5. Fold both ends of tissue runner into box

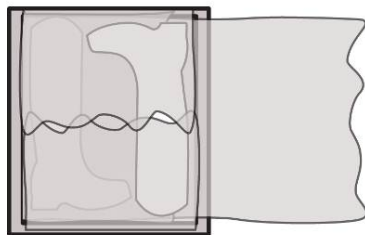

6. Fold other end of tissue wrap into box

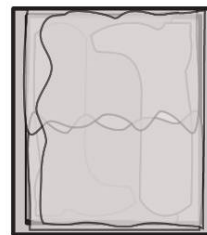

5/28/13

MINIMUM PACKING AND PRESENTATION STANDARDS

Any exception to the below Minimum Packaging and Presentation Standards need to be presented to and approved by TD and PD, with approval noted on confirmation checklist, 6-8 weeks prior to x-factory.

Kohl's Standard Packaging: Folded Boots without Support*

Ref. # 5

*A support is REQUIRED if a crease remains in the boot after it has been unfolded. The support is meant to prevent this.

1. Apply 2 Micro-Pak stickers, one on each long side of shoebox in the upper corner, at the same end of shoebox that the retail label is attached

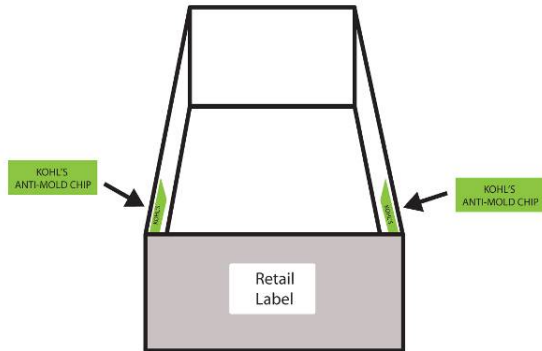

2. Tissue wrap length (1PC)=
 $2 \times \text{box width} + 3 \times \text{box height}$
 Tissue runner length (1PC)=
 $2 \times \text{box length} + 2 \times \text{box height}$

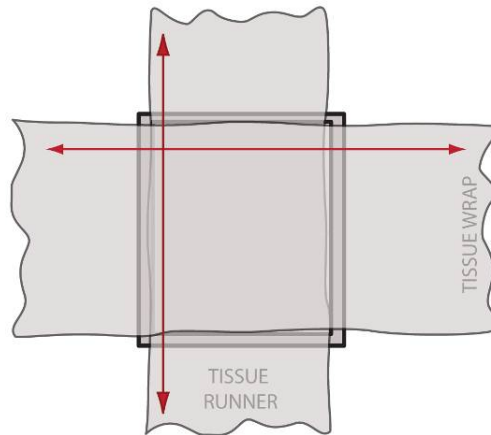

2. Place folded boot **heavy side up** into box against one end.

3. Place full sheet of recycled paper board divider into box over boot and place second boot on top of the divider

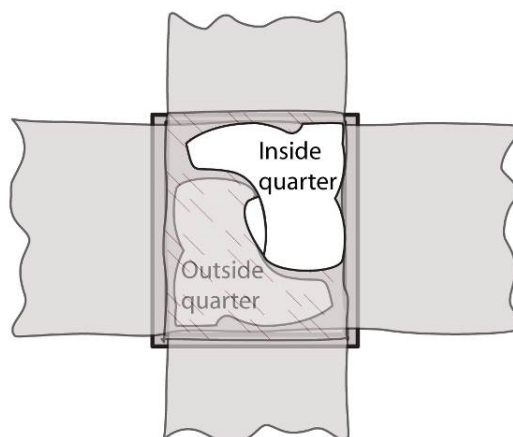
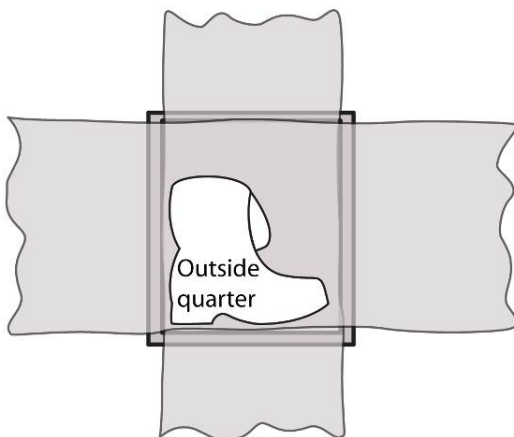

5. Fold both ends of tissue runner into box,

6. Fold both ends of tissue wrap into box, one sheet overlapping the other.

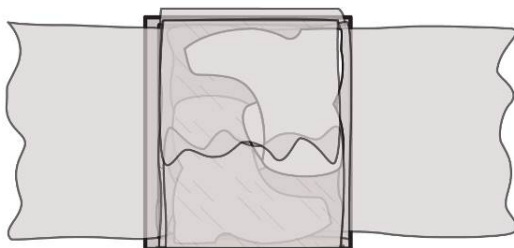

8/06/13

MINIMUM PACKING AND PRESENTATION STANDARDS

Any exception to the below Minimum Packaging and Presentation Standards need to be presented to and approved by TD and PD, with approval noted on confirmation checklist, 6-8 weeks prior to x-factory.

Kohl's Standard Packaging: Folded Boots with Support*

Ref. # 6

*A support is REQUIRED if a crease remains in the boot after it has been unfolded. The support is meant to prevent this.

1. Apply 2 Micro-Pak stickers, one on each long side of shoebox in the upper corner, at the same end of shoebox that the retail label is attached

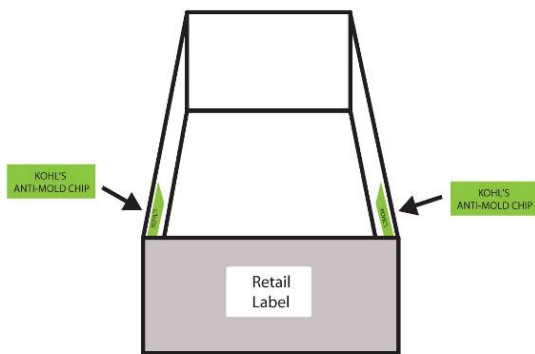

2. Tissue wrap length (1PC)=
 $2 \times \text{box width} + 3 \times \text{box height}$
 Tissue runner length (1PC)=
 $2 \times \text{box length} + 2 \times \text{box height}$

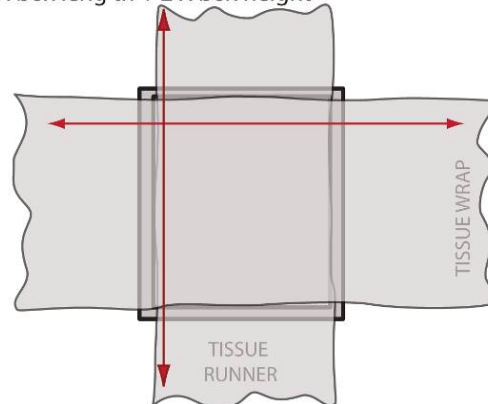

3. In order to protect the shaft fold from getting creased, please use either a paperboard roll or cylinder shaped tissue roll. **Proceed by folding one boot shaft toward inside quarter, and the other boot shaft towards the outside quarter**

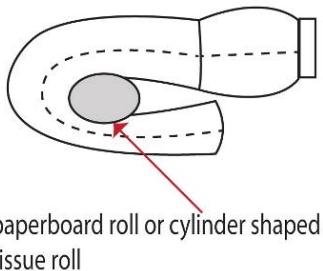

4. Place folded boot **heavy side up** (see picture #2) into box against one end. Folding the boot heavy side up allows for the paperboard roll or paper tissue roll to stay in place at the crease of the boot shaft during transit

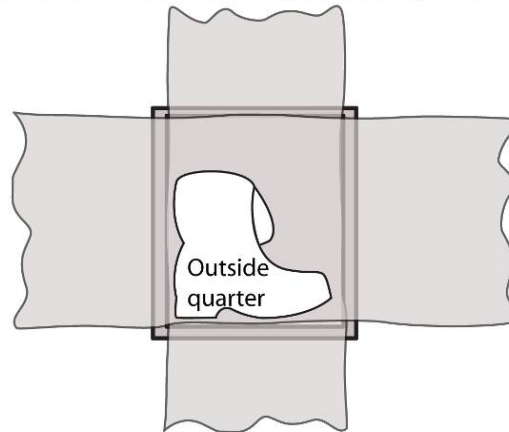

5. Place full sheet of recycled paper board divider into box over boot and place second boot on top of the divider

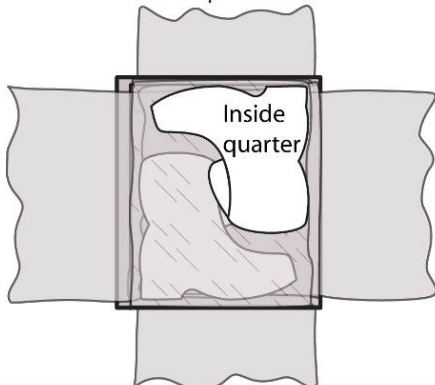

6. Fold both ends of tissue runner into box

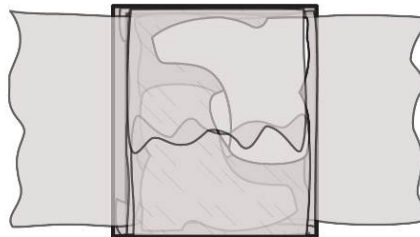

7. Fold both ends of tissue wrap into box, one sheet overlapping the other.

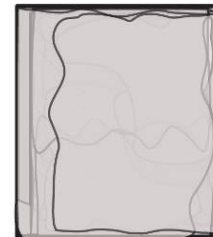

8/06/13

MINIMUM PACKING AND PRESENTATION STANDARDS

Any exception to the below Minimum Packaging and Presentation Standards need to be presented to and approved by TD and PD, with approval noted on confirmation checklist, 6-8 weeks prior to x-factory.

Kohl's Standard Packaging: Genuine Suede Footwear

Ref. # 7

1. Tissue wrap length (1PC)=
 $2 \times \text{box width} + 3 \times \text{box height}$

Tissue runner length (1PC)=
 $2 \times \text{box length} + 2 \times \text{box height}$

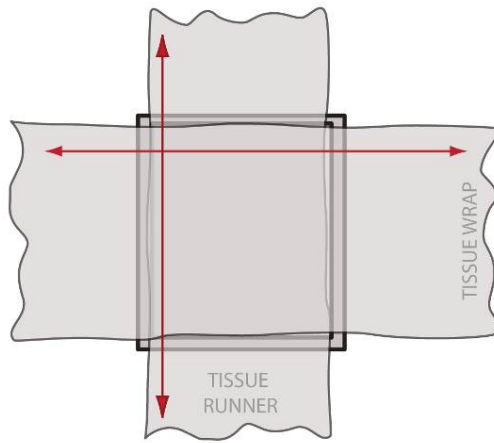

2. Place Micro-Pak Enhanced PE sheet on bottom of box and place shoe on top

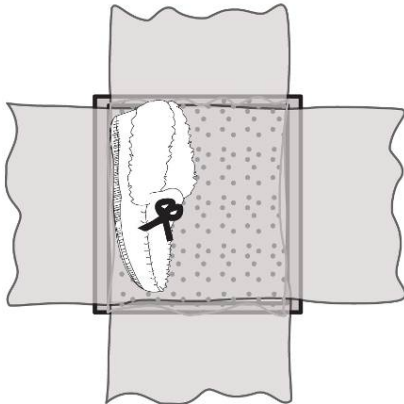

3. Fold tissue on top of shoe to act as a divider and place second shoe in box

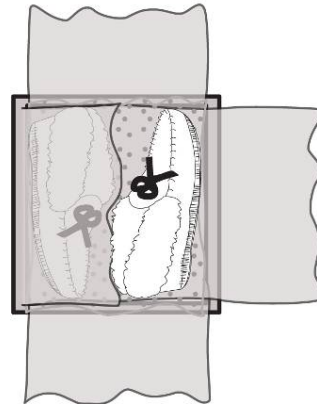

5. Fold both ends of tissue runner into box

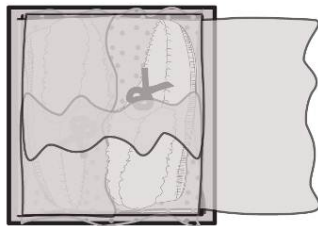

6. Fold other end of tissue wrap into box

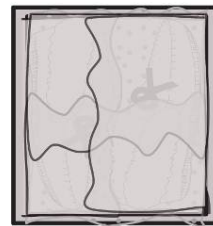

8/07/13

MINIMUM PACKING AND PRESENTATION STANDARDS

Any exception to the below Minimum Packaging and Presentation Standards need to be presented to and approved by TD and PD, with approval noted on confirmation checklist, 6-8 weeks prior to x-factory.

Kohl's Standard Packaging: Genuine Suede Boots

Ref. # 8

1. Tissue wrap length (1PC)=
 $2 \times \text{box width} + 3 \times \text{box height}$
Tissue runner length (1PC)=
 $2 \times \text{box length} + 2 \times \text{box height}$

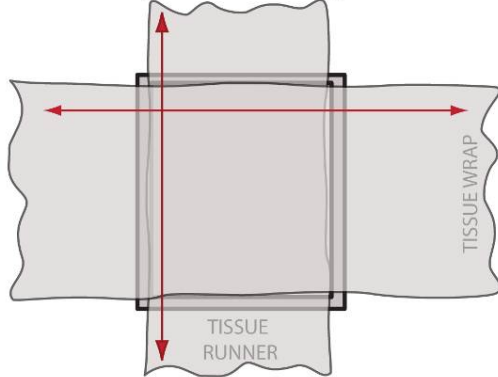

2. Place boot into box against one end and place a Micro-Pak Enhanced PE sheet on top of boot

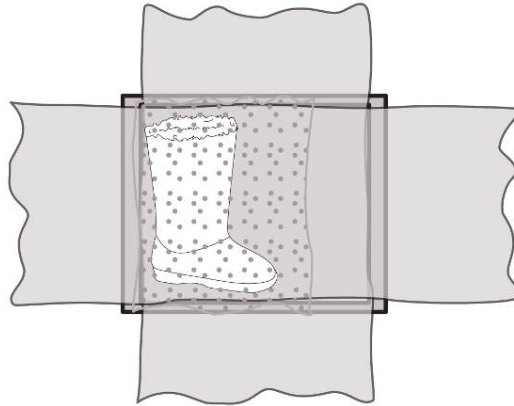

3. Fold tissue wrap on top of boot to act as a divider

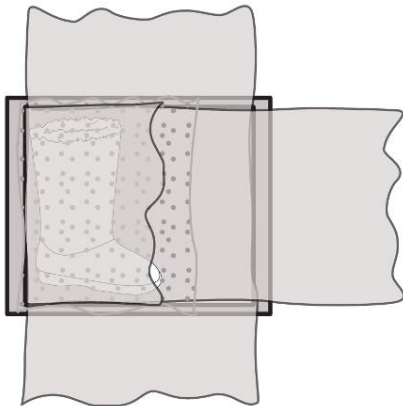

4. Place second boot in box and place second Micro-Pak Enhanced PE sheet on top of boot

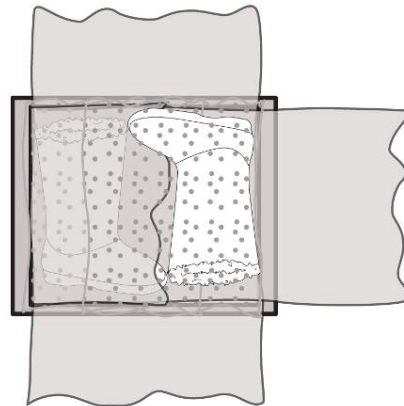

5. Fold both ends of tissue runner into box

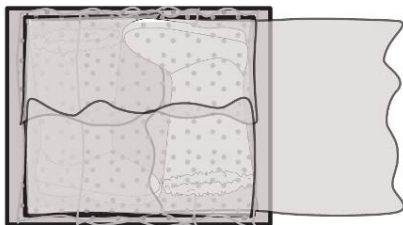

6. Fold other end of tissue wrap into box

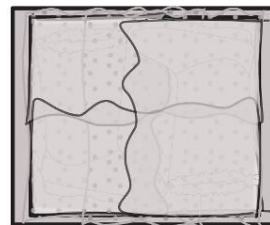

8/07/13

MINIMUM PACKING AND PRESENTATION STANDARDS

Any exception to the below Minimum Packaging and Presentation Standards need to be presented to and approved by TD and PD, with approval noted on confirmation checklist, 6-8 weeks prior to x-factory.

Kohl's Standard Packaging Instructions for Hanging Styles Ref. # 9 Plastic Hanger: Hangtag Tied to Upper

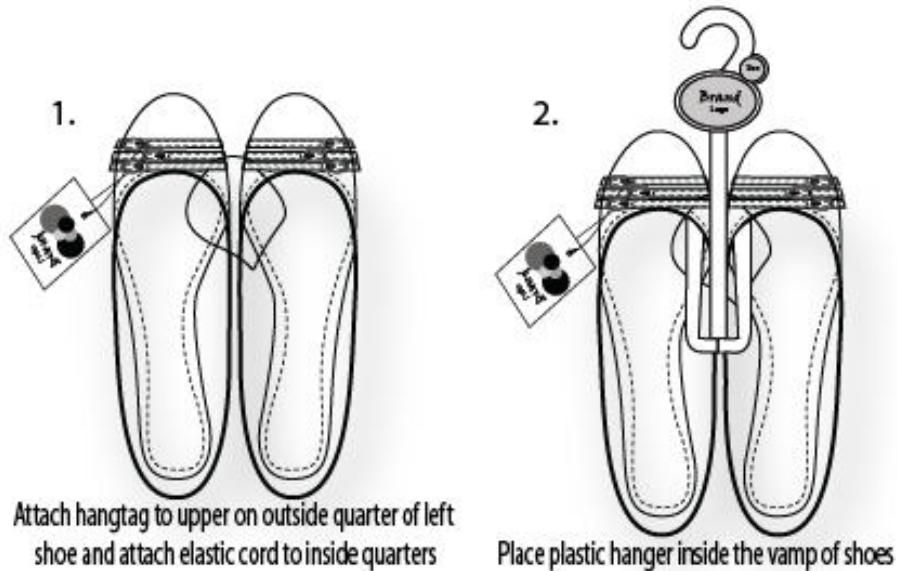

MINIMUM PACKING AND PRESENTATION STANDARDS

Any exception to the below Minimum Packaging and Presentation Standards need to be presented to and approved by TD and PD, with approval noted on confirmation checklist, 6-8 weeks prior to x-factory.

Kohl's Standard Packaging Instructions for Hanging Styles **Ref. # 10**

Plastic Hanger: Hangtag Tied to Topline Loop

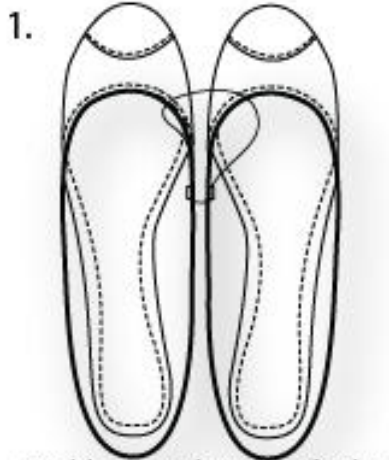

Attach loop to inside quarters of topline and attach elastic cord through loops

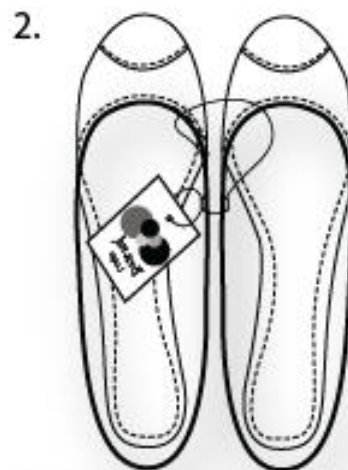

Attach hang tag to topline loop on left shoe
DO NOT attach hang tag through elastic chord

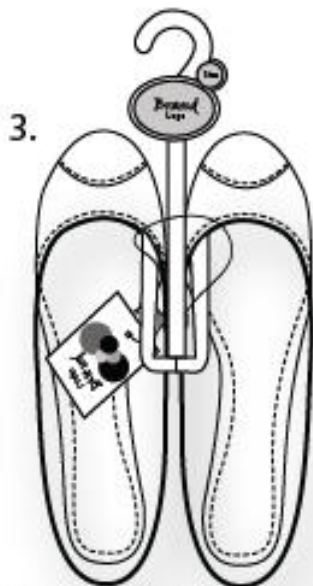

Place plastic hanger inside the vamp of shoes

MINIMUM PACKING AND PRESENTATION STANDARDS

Any exception to the below Minimum Packaging and Presentation Standards need to be presented to and approved by TD and PD, with approval noted on confirmation checklist, 6-8 weeks prior to x-factory.

Kohl's Standard Packaging Instructions for Hanging Styles Ref. # 11

Plastic Hanger: Hangtag Tied to Insole Loop

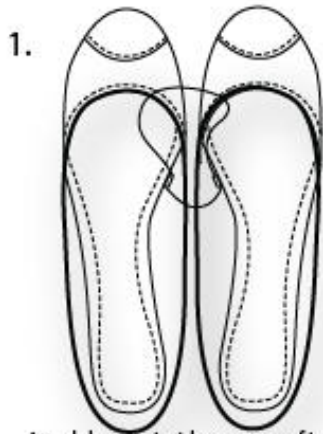

Attach loop to inside quarters of insole and attach elastic cord through loops

3.

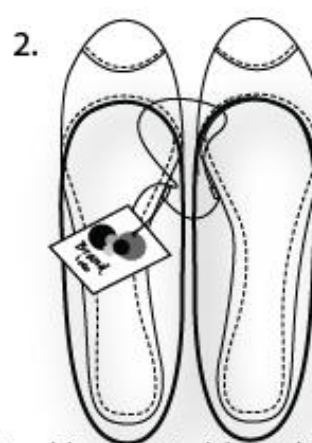

Attach hang tag to insole loop on left shoe
DO NOT attach hang tag through elastic chord

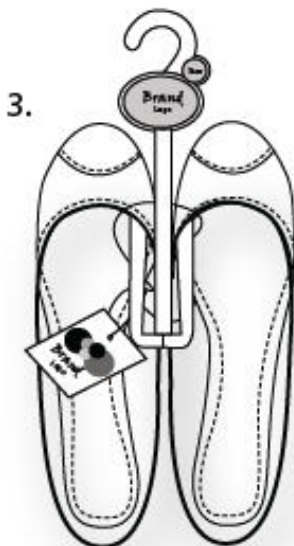

Place plastic hanger inside the vamp of shoes

MINIMUM PACKING AND PRESENTATION STANDARDS

Any exception to the below Minimum Packaging and Presentation Standards need to be presented to and approved by TD and PD, with approval noted on confirmation checklist, 6-8 weeks prior to x-factory.

Kohl's Standard Packaging Instructions for Flip Flops

Ref.# 12

Plastic Hanger: No Additional Packaging

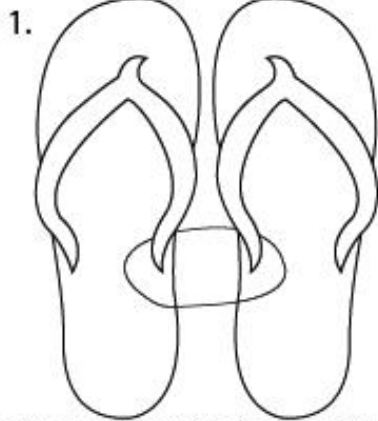

Attach elastic cord through inside quarters of upper

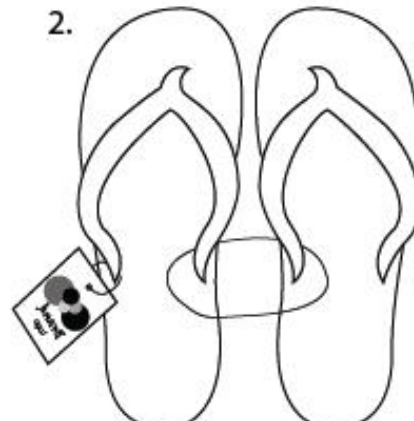

Attach hang tag to outside quarter of upper on left shoe
DO NOT attach hang tag through elastic chord

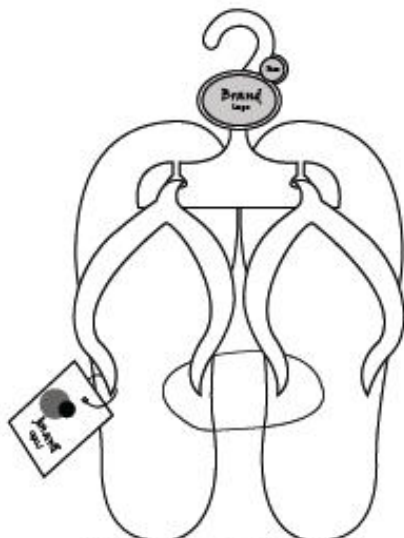

Place flip flops on plastic hanger

MINIMUM PACKING AND PRESENTATION STANDARDS

Any exception to the below Minimum Packaging and Presentation Standards need to be presented to and approved by TD and PD, with approval noted on confirmation checklist, 6-8 weeks prior to x-factory.

Kohl's Standard Packaging Instructions for Flip Flops

Ref. # 13

Plastic Hanger: Foam Toe Thong Support

1.

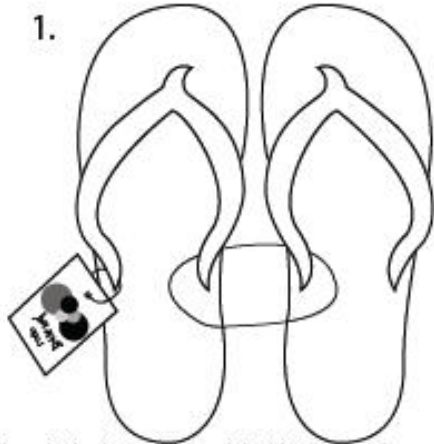

Attach elastic cord through inside quarters of upper
Attach hang tag to outside quarter of upper on left shoe
DONOT attach hang tag through elastic chord

2.

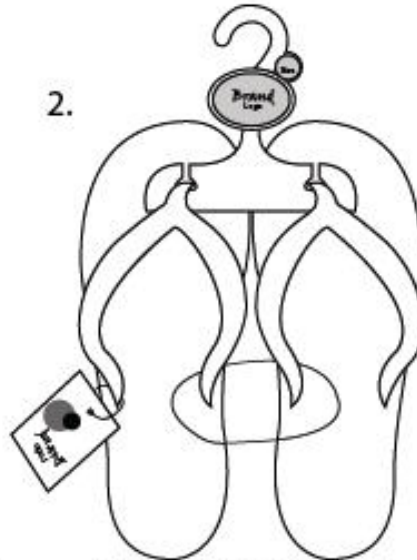

Place flip flops on plastic hanger

3.

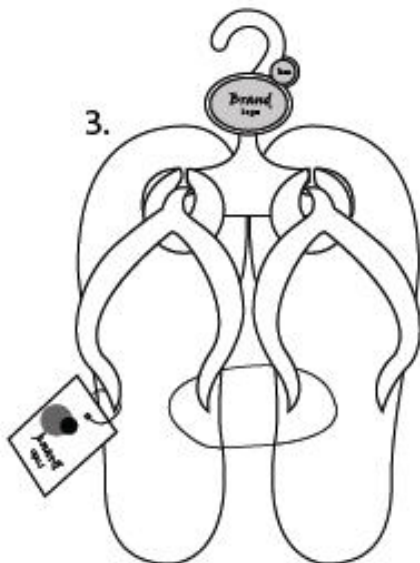

Place plastic toe thong supports around
toe thong and on top of hanger

MINIMUM PACKING AND PRESENTATION STANDARDS

Any exception to the below Minimum Packaging and Presentation Standards need to be presented to and approved by TD and PD, with approval noted on confirmation checklist, 6-8 weeks prior to x-factory.

Kohl's Standard Packaging Instructions for Hanging Styles **Ref.# 14** Plastic Hanger: Skimmer Slippers

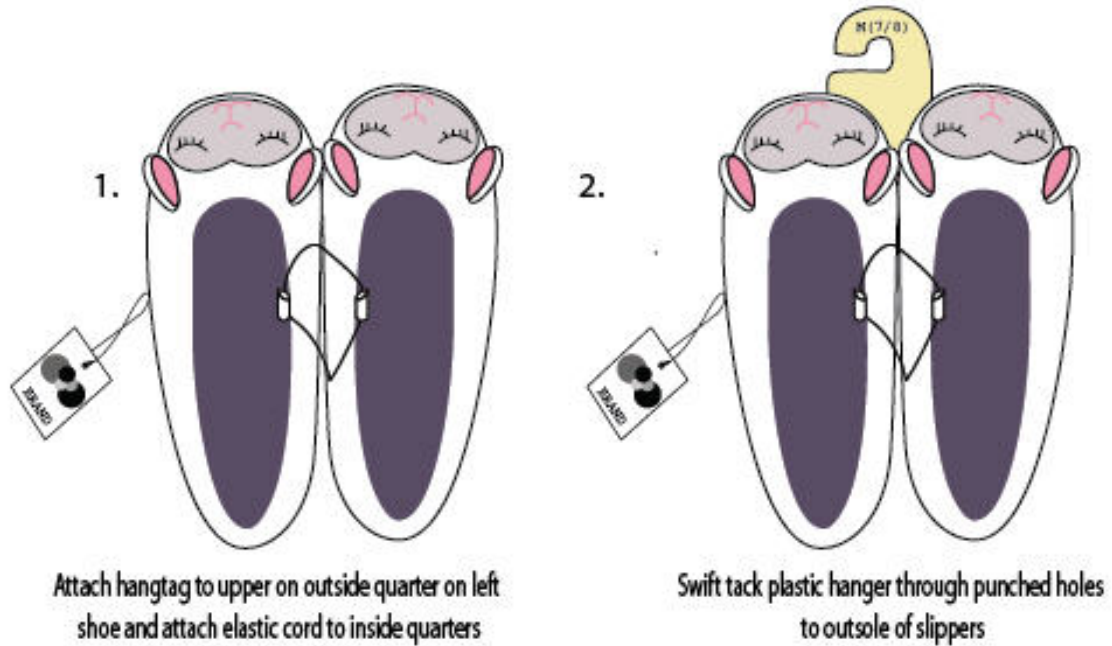

MINIMUM PACKING AND PRESENTATION STANDARDS

Any exception to the below Minimum Packaging and Presentation Standards need to be presented to and approved by TD and PD, with approval noted on confirmation checklist, 6-8 weeks prior to x-factory.

Kohl's Standard Packaging Instructions for Hanging Styles Ref.# 15

Plastic Hanger: Clog Slippers

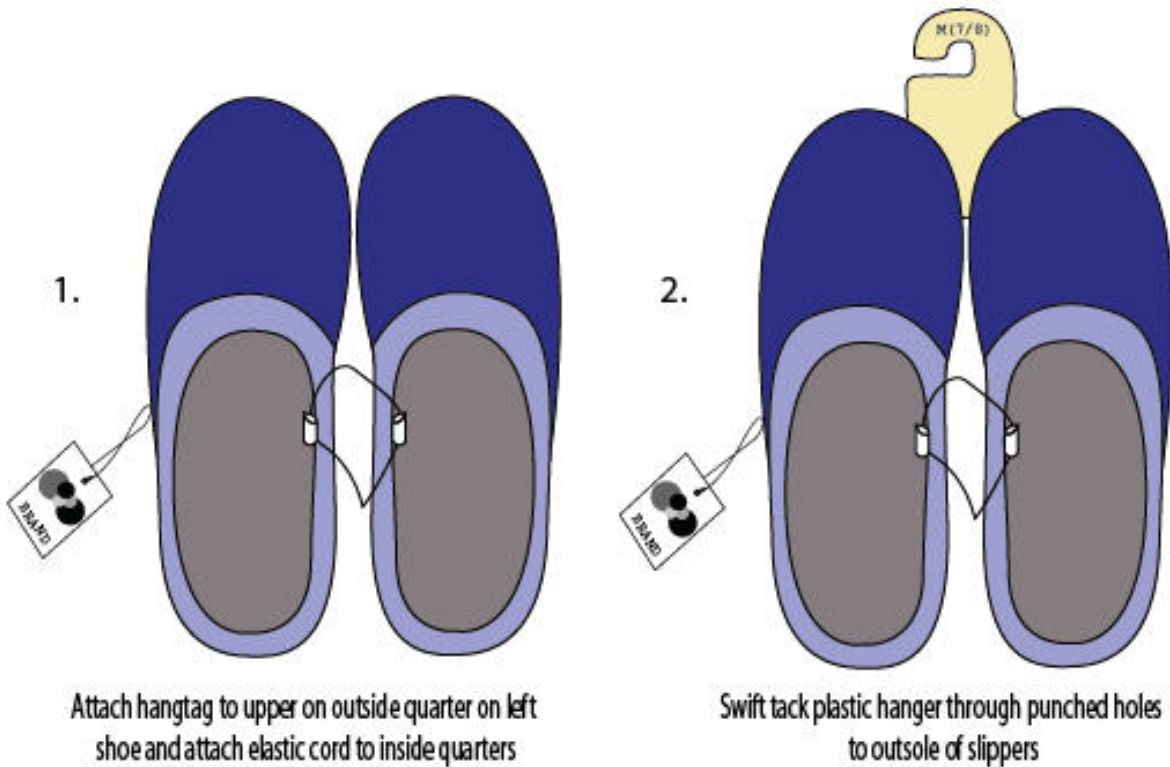

MINIMUM PACKING AND PRESENTATION STANDARDS

Any exception to the below Minimum Packaging and Presentation Standards need to be presented to and approved by TD and PD, with approval noted on confirmation checklist, 6-8 weeks prior to x-factory.

Kohl's Standard Packaging Instructions for Hanging Styles Ref.# 16

Plastic Hanger: Slipper Boots

1.

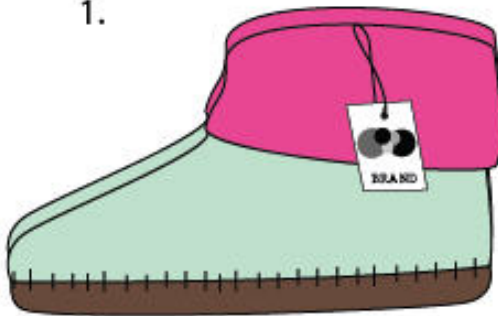

Attach hangtag to upper on outside quarter on left boot and attach elastic cord to inside quarters

2.

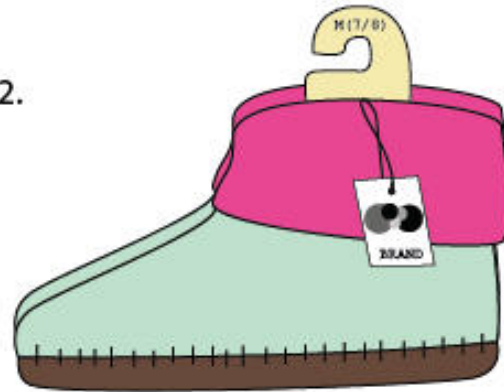

Swift tack plastic hanger through punched holes to outsole of slippers

MINIMUM PACKING AND PRESENTATION STANDARDS

Packing Requirements

Sample Packing

“Best Practice” Packing Guidelines for Napped Upper Footwear

Prior to packaging any footwear with napped uppers (including both suede and microfiber), uppers should be brushed clean of any dirt or lint that has collected from the production line. We discourage the use of air to blow lint from uppers, as this puts the lint particles back into the air, and increases the chance of other shoes picking up lint. This **“best practice”** should be followed whether the shoes will be polybagged in pairs (hanging programs) or packed directly into a shoebox with only tissue.

Foam Toe Thong Support Options



Polyethylene (EPE) Foam

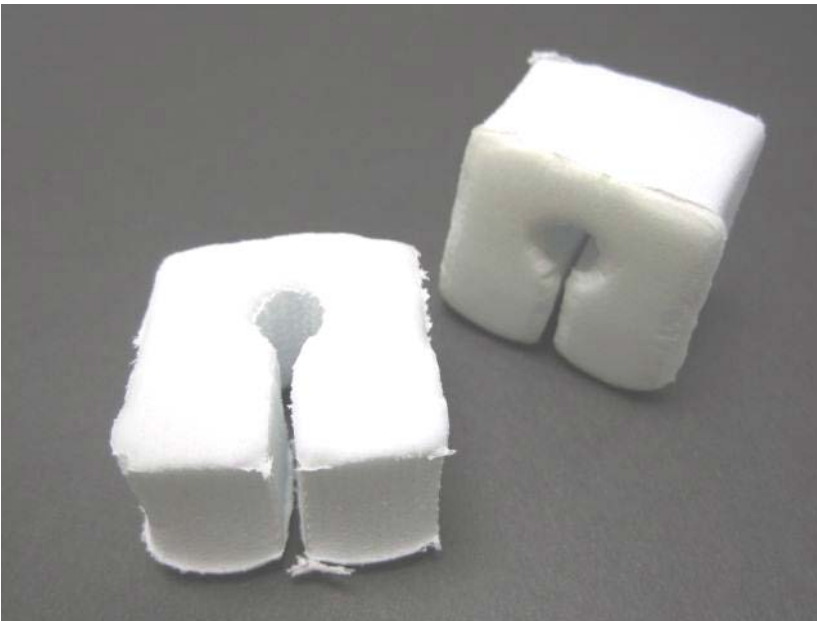

Ethel Vinyl Acetate (EVA) Foam

MINIMUM PACKING AND PRESENTATION STANDARDS

General guidelines for paper tissue used to stuff vamps/uppers:

Manufacturers may use their own generic white tissue for the stuffing of vamps after submitting a sample to KOHL'S for approval.

General guidelines for recycled paperboard divider:

Content: 90% recycled material

Weight: 300gsm CCNB

Color: 16pt. white coated on one side, uncoated gray for the other side

Recycled paperboard divider size varies by shoebox size. Divider should be approximately the length of the diagonal of the box and the height of the depth of the box.

MINIMUM PACKING AND PRESENTATION STANDARDS

Engineered Bamboo Topline Sticks



SUPPLIERS:

Wellspring Industrial Company.

B53 Wusong Street

Dongcheng Town

Dongguan City

Guangdong Province, China

Contact: Mr. Chen

PH: 13829237339

Email: yihui-88888@163.com

Or

Nan Jump Paper-Product Co., Ltd

Xia Dong Industrial park, Ping Liu Road, Pingzhou Nanhai Foshan City,

Guangdong China

Tel: 86-757-86229668 / 86322161

Fax: 86-757-86221198

Contact -1: Alex Ko

Cell: 86-13322844698

Email: alex@boxes-shop.com

Contact - 2: Wei Lo

Cell: 86-13326751220

Email: nanjump@boxes-shop.com

MINIMUM PACKING AND PRESENTATION STANDARDS

Polybag Guidelines

Polybags w/Suffocation Warning for Individually Polybagged Footwear Placed Inside of Shoeboxes.

Content: polyethylene film (do not use polypropylene)

Thickness: 1.5 mil

Size: Dimensions will vary depending on the style of footwear. However the length should be 4 inches longer than the shoe so that the open end of the bag can be folded over at the heel.

The following **suffocation warning** must be printed directly on each polybag:

“WARNING: TO AVOID DANGER FROM SUFFOCATION, KEEP THIS BAG AWAY FROM BABIES AND CHILDREN!”

Type Face: 12 point (minimum), Arial, bold

Ink Color: black

6 mm diameter holes must be punctured into each bag along each folded edge, spaced at 3” intervals, starting from the bottom of the bag.

Example:

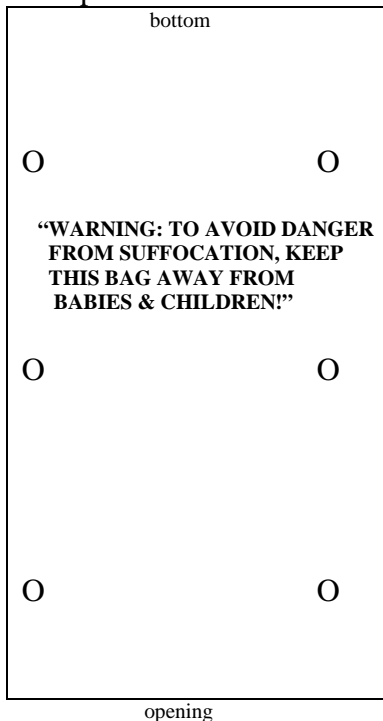

MINIMUM PACKING AND PRESENTATION STANDARDS

Shipping Carton Polybag Liners w/suffocation warning used for retail store, hanging footwear orders.

Content: polyethylene film (do not use polypropylene)

Thickness: 4.0 mil

Size: Dimensions will vary depending on the size of the shipping carton. Bag bottom is a flat panel. The polybag liner must be long enough so it can be folded over after the carton is filled, completely enclosing/covering the carton contents.

The following **suffocation warning** must be printed directly on each polybag:

**“WARNING: TO AVOID DANGER FROM SUFFOCATION,
KEEP THIS BAG AWAY FROM BABIES AND CHILDREN!”**

Type Face: 12 point (minimum), Arial, bold

Ink Color: black

6 mm diameter holes must be punctured into each bag along each folded edge, commonly spaced at 5 cm (approx. 2”) intervals, starting from the bottom of the bag.

Example:

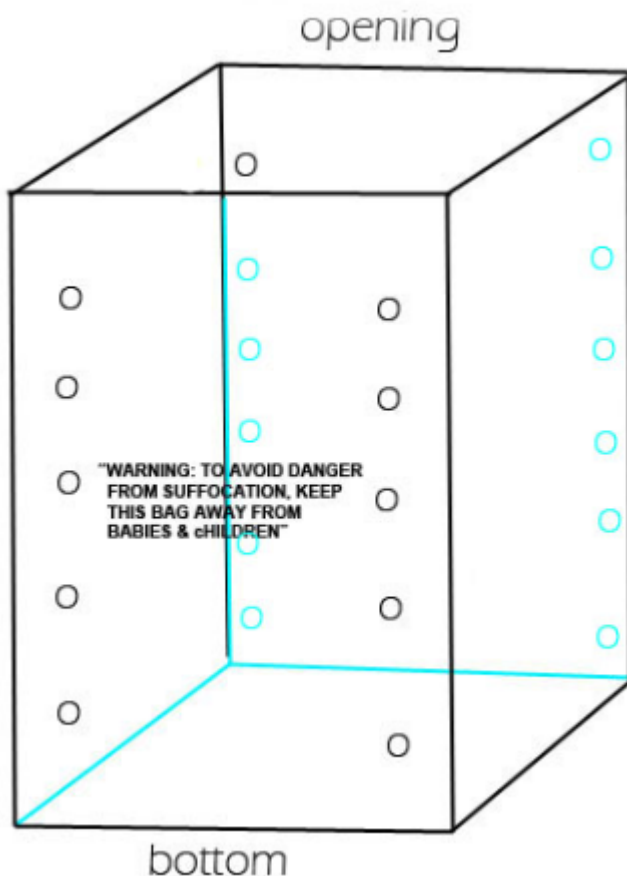

MINIMUM PACKING AND PRESENTATION STANDARDS

Shipping carton with internal polybag liner & dividers for shipping hanging program footwear (store orders). Footwear pairs are not placed in individual polybags for retail store orders, only for Ecommerce orders.

NOTE: "E-commerce specific POs require packaging specific to the Kohl's e-commerce fulfillment process. The requirements can be found within the vendor portal (K-Link).



MINIMUM PACKING AND PRESENTATION STANDARDS

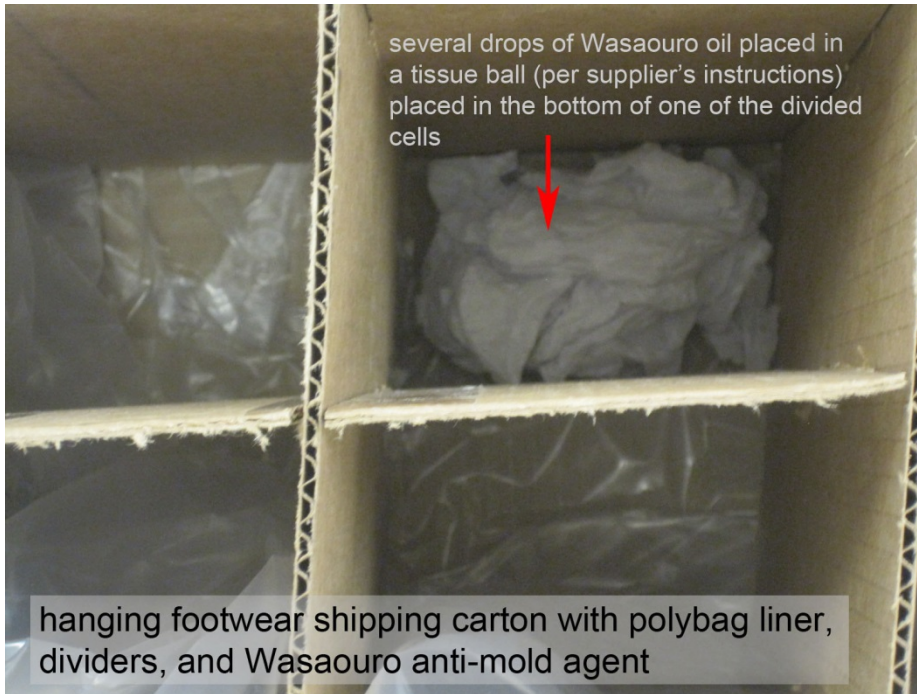

MINIMUM PACKING AND PRESENTATION STANDARDS

The polybag liner must be long enough so that after the carton is packed, the bag can be folded over so it covers all of the footwear inside.



hanging footwear carton with polynbag liner & dividers

MINIMUM PACKING AND PRESENTATION STANDARDS

Shoebox Requirements

Micro-Pak Guidelines

Anti-Bacterial / Anti-Fungal Packaging Guidelines

Attached to middle corner of left long side of shoebox, at the same end that the retail label is attached. On boot boxes when two chips are needed, the second chip should be placed directly across from the first, still on the long side of the box, regardless of where the second retail sticker is placed. Use **Micro-Pak®** or **Wasaouro®** self-adhesive Anti-Bacterial / Anti-Fungal chips w/ KOHL'S logo. **DO NOT USE** silica gel packets or any other brands of anti-mold chips.

Shoe box sticker placement



Boot box sticker placement

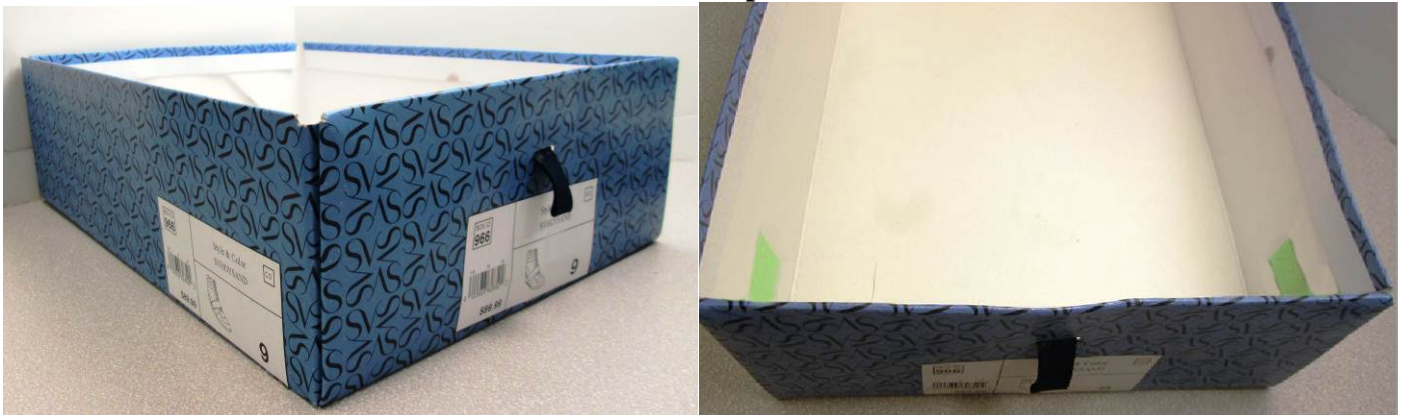

MINIMUM PACKING AND PRESENTATION STANDARDS

Slipper box sticker placement



MINIMUM PACKING AND PRESENTATION STANDARDS

Micro-Pak® self-adhesive chips with KOHL'S logo.
Actual size: 2" (W) x 1" (H) with embossed printing



Micro-Pak® Anti-Bacterial / Anti-Fungal Enhanced PE Sheets – **25 cm X 25 cm**
For footwear individually polybagged inside of shoeboxes: 1 PE sheet inserted with shoes, into each polybag. Also used instead of a chip for all suede footwear.

Micro-Pak® Enhanced PE Sheet

Sheet Sizes	Order Unit (Pieces)
16 cm X 8 cm	5,000 pcs (1 pouch)
25 cm X 25 cm	1,000 pcs (1 pouch)
60 cm X 40 cm	1,000 pcs (10 pouches)
160 cm X 60 cm	1,000 pcs (20 pouches)

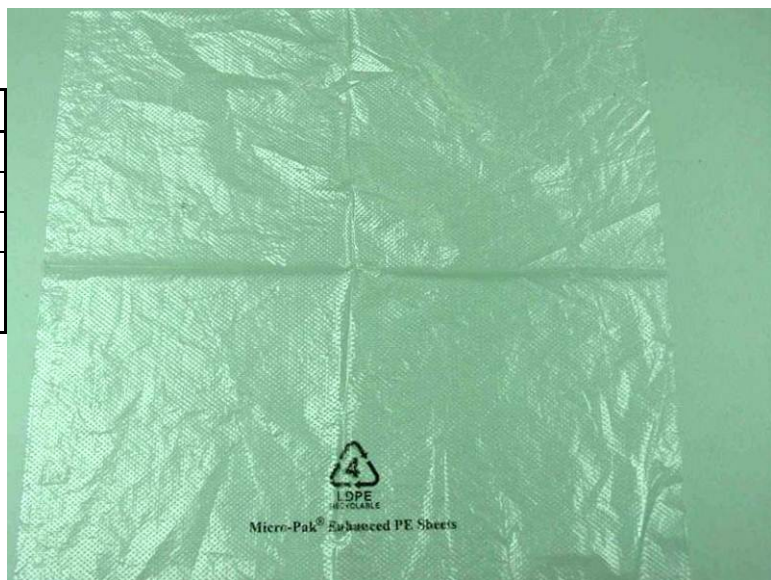

Martin Berman
Micro-Pak Ltd.
Website <http://www.micropakltd.com>
Tel: (852) 2956 2991 Fax: (852) 2956 0790
E-mail: martin.berman@micropakltd.com

MINIMUM PACKING AND PRESENTATION STANDARDS

Anti-Bacterial/Anti-Fungal Wasaouro Guidelines

Anti-Bacterial / Anti-Fungal **WASAOURO** Oil and Chip

Wasaouro oil applied to tissue placed inside the shipping cartons (boxed footwear) or shipping carton liners (hanging footwear programs) following supplier's instructions.



Contact information: Only contact persons and offices as follows otherwise you will be buying counterfeit product.

Company Name : Chifa Auto Products Corp. Wasaouro --- USA Website: <http://www.chifa.com.tw>

Address: 12 Copperfield, Bentonville, Arkansas 72712 USA.

Phone: +1-479-426-6724

Contact Name: Mr. Rick Garrison

Email: rickg1352@gmail.com

Wasaouro Taiwan – Taipei Head Office

Address : 15F-3, No. 7, Section 3, New Taipei Blvd, Xinzhuang District, New Taipei City 242, Taiwan.

Phone: +886-2-8522-7111 Ext. 208

Fax: +886-2-8522-7011

Contact Name : Ms. Ame Chen

Email: ame@chifa.com.tw

or

Phone: +886-2-8522-7111 Ext. 301

Fax: +886-2-8522-7011

Contact Name : Mr. Nelson Ruan

Email: nelson.ruan@chifa.com.tw

Wasaouro China – Houjie Office

Address: #1 Building, No. 5, Hongshan Road, Bai Hau Tsun, Houjie Town, DongGuan City, Guangdong Province, China.

Phone: +86-135-8088-8058

Fax: +86-769-8575-0685

Phone: +86-769-8596-5081

Contact Name : Mr. Tony Fang

Email: tony@chifa-auto.com

Wasaouro Taiwan – Changhua Office

Address: No.9-2, Tianzhongyang Lane, Yuanlin Town, Changhua County, Taiwan.

Phone: +886-4-8337721

Fax: +886-4-8337713

Contact Name: Ms. Candy Su

Email: candy@chifa.com.tw

MINIMUM PACKING AND PRESENTATION STANDARDS

Best Practice for Wasaouro Application



Place Wasaouro roll into dispenser box.

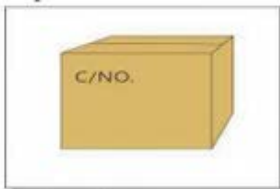

Shipping Cartons must be taped & sealed air tight with no gaps immediately after packing.

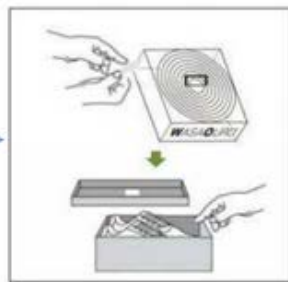

Apply Wasaouro adhesive strip to center of each box lid after the open box and lid have passed through the UV light box, and immediately after the shoes are placed inside the box.

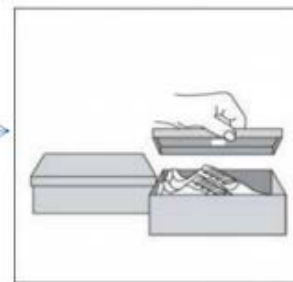

Close shoe box lid immediately.



Unused Wasaouro should be placed back in the aluminum bag & re-sealed.

Best Practice of Wasaouro YL Application for Polybag Packaging

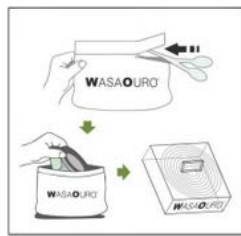

Place Wasaouro YL roll into dispenser box.



Sealed polybag immediately

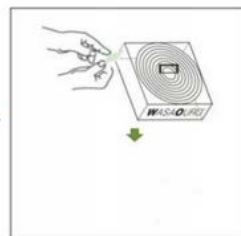

Tear off one piece of Wasaouro YL



Shipping Cartons must be taped & sealed air tight with no gaps immediately after packing.



Put Wasaouro YL into polybag



Unused Wasaouro YL should be placed back in the aluminum bag & re-sealed.